

BRK[®]

THE PROFESSIONAL STANDARD

RF INTERLINK BASE DS700RF

IMPORTANT: Please read this manual before installation.
If installing the alarm for others please leave a copy for the
end user.

CE



5 Year
Guarantee

CONTENTS

- 1.** Introduction
- 2.** Quick installation guide
- 3.** Installation guide
 - 3.1** DS700RF installation and set-up
 - 3.2** Learning in a new system
 - 3.3** Learning in an additional unit to an existing DS700RF system
- 4.** Operating conditions
- 5.** Trouble shooting
- 6.** Disposal
- 7.** Limited guarantee
- 8.** Technical specification

1. INTRODUCTION

This DS700RF RF interlink base is designed to be used in conjunction with any BRK mains operated Smoke and Heat alarms in the **670, 650, 680** series **ONLY**.

Interlinked Smoke and Heat alarms which utilise RF interlink technology have the benefit of being able to be used in a Grade D or E alarm system without the need for hardwiring connection between each alarm in the system. This is particularly useful when refurbishing or extending a property and allows the Grade D or E system to be wired by way of the un-switched part of a local lighting circuit or independent circuits at the dwelling's main distribution board (ref BS5839 Part 6).

The DS700RF utilises a unique system which provides in excess of 16 million separate ID codes, one of which is automatically selected when the system is learnt in on installation. The high number of alternative codes helps prevent individual systems in separate properties from interfering with one another and resulting in unwanted nuisance alarms. Utilising the DS700RF allows up to 50 alarms to be interlinked in each system.

2. QUICK INSTALLATION GUIDE

- a) Install each DS700RF base in an appropriate position at least 300mm from the nearest light fitting (ref Smoke/Heat alarm instructions) and connect to the nearest mains circuit. DO NOT SWITCH ON MAINS POWER.
- b) Learn in each base by pressing the button (See **Fig 1**) using a small screwdriver.
- c) Plug in the Smoke and Heat alarms as appropriate onto each base (See **Fig 2**). Switch on mains power.
- d) Ensure that at least 2 minutes has elapsed before pressing the test button on each alarm. When the test button on one of the alarms is pressed all of the other alarms in the system should sound within 10 seconds.

Fig 1.

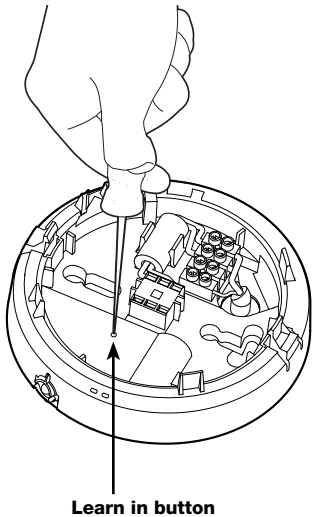
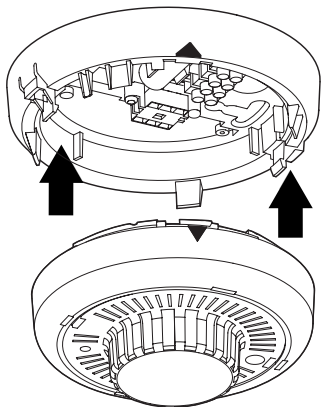

Fig 2.



3. INSTALLATION GUIDE

Please consult the Smoke/Heat alarm owner's manual for details of where and where not to site your Smoke and Heat alarms.

WARNING: Wiring should be installed by a qualified electrician in accordance with BS7671. Permanent connection to the fixed wiring of the building should be made in a suitable junction box. This alarm must not be exposed to dripping or splashing. Connect the alarm as late as possible in an installation, particularly in new build, to avoid contamination. Remove the dust cover before applying power.

3.1) DS700RF INSTALLATION AND SETUP

Fig 3.

Live = Brown

Neutral = Blue

Earth

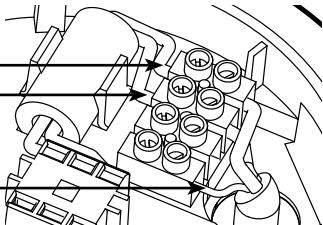

- a) Install the DS700RF docking base on the ceiling no closer than 300mm from the nearest light fitting. Always refer to your Smoke/Heat alarm manual for positioning and installation guidance.
- b) Bring wires through either the YT2 trunking knockout on the side of the base or the knockout in the base itself and install the wires into the connector terminals marked L (live), Neutral (N) and Earth (E). See Fig 3.
- c) Install ALL bases that will be required in the system in their appropriate positions.

IMPORTANT: The circuit used to power the alarm must be a constant 230V AC 50Hz voltage circuit that cannot be turned off by a switch. BS5839 Part 6 states that:

For mains powered alarms, each with an integral standby supply (Grade D), the mains electricity supply should take the form of either:

- 1) An independent circuit at the dwelling's main circuit board, in which case no other electrical equipment should be connected to this circuit (other than a dedicated monitoring device installed to indicate failure of the mains electricity supply to the alarms); or

- 2) A separately electrically protected, regularly used local lighting circuit. For mains powered alarms with no standby supply (Grade E), the mains electricity supply may only take the form of an independent circuit as per 1) above. If it is necessary to use an RCD for protection, it should operate independently of any RCD protection for circuits supplying sockets or portable equipment. All interconnected alarms should be installed on a single final circuit.

3.2) LEARNING IN A NEW SYSTEM

Fig 4.

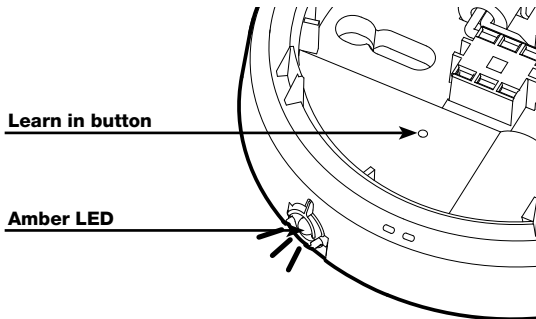

NOTE: The system must be learnt in before the alarms are installed on the base.

- a) Locate the push button on an installed DS700RF and press briefly using a small screwdriver (see Fig 1). The amber LED will illuminate for 3 seconds to indicate that it is activated. (See Fig 4). The buzzer will also give an audible ‘chirp’ to show that it is working.
- b) Repeat this process on every remaining DS700RF required to be in the system. As each alarm is successfully learnt in the amber LED will start to flash once every 3 seconds.

NOTE: The DS700RF allows for a period of 15 minutes during which all bases need to be learnt in.

- c) Once all bases are learnt in, install Smoke/Heat alarms onto each DS700RF as outlined in the owner’s manual (See **Fig 2**).
- d) Turn on mains power.
- e) Ensure all Smoke/Heat alarms in the system display a green power light and red operating light as per the Smoke/Heat alarm manual.

- f) Ensure the amber LED on every DS700RF flashes once every three seconds.
- g) Press the test button on each alarm in the system in turn and ensure 1) the alarm sounds and 2) it links with every other alarm in the system.
- h) Installation is now complete.

NOTE: If all DS700RF bases have been learnt in before 15 minutes has elapsed, pressing the test button on any installed Smoke/Heat alarm will cause the learn in procedure to finish early. This will also test every alarm in the system. The amber LED on every DS700RF will flash twice every 3 seconds for a period of 5 minutes after the learn in process has completed.

If after a period 15 minutes a unit has failed to learn in, it will sound a double beep for a period of 5 minutes.

3.3) LEARNING IN AN ADDITIONAL UNIT TO AN EXISTING DS700RF SYSTEM

If you require an additional alarm to be added to an existing DS700RF system:

- a) Following section **3.1**, install the new DS700RF in the required location.
- b) Restore mains power to all the installed alarms and the new DS700RF.
- c) Locate the push button on the new DS700RF and press briefly using a small screwdriver. The amber LED will illuminate for 3 seconds to indicate it has been activated. The buzzer will also give an audible 'chirp' to show that it is working.

NOTE: If the existing Smoke/Heat alarms in the property are mains only powered, it is important that they remain connected with the mains power on during step (d).

- d) Press the test button on one of the alarms in the existing system long enough to trigger the other alarm(s) in the system. This should be carried out within 5 minutes.
- e) Wait until the amber LED on the new DS700RF flashes twice every 3 seconds. This indicates that the learn in process has completed.
- f) Before you install the new Smoke/Heat alarm, isolate the mains power once again.

- g)** Install the new Smoke/Heat alarm onto the DS700RF as outlined in the alarm owner's manual (See **Fig 2**).
- h)** RESTORE MAINS POWER TO ALL ALARMS. Ensure all Smoke/Heat alarms in the system display a green power light and red operating light as per the user's manuals.
- i)** Press the test button on the new alarm in the system to ensure that 1) the alarm sounds and 2) it links with the existing alarms in the system.

NOTE: The amber LED will stop flashing 5 minutes after the learn in process has completed. Test (i) should be carried out regardless of this.

- j)** Installation is now complete.

NOTE: If after a period 15 minutes the unit has failed to learn in, it will sound a double beep for a period of 5 minutes.

4. OPERATING CONDITIONS

Amber operating LED: Located on the side of the DS700RF, this LED will remain off during normal working conditions. Any fault with the DS700RF will be indicated by a flash of the LED and a single chirp.

Low battery warning: When a low battery condition on the DS700RF occurs the internal buzzer will chirp along with a single flash of the amber LED once every minute, for a period of at least 30 days.

IMPORTANT: The DS700RF has a sealed in battery and circuitry therefore should you encounter a fault warning the DS700RF will need to be replaced. As with all work involving electrical wiring always consult a qualified electrician.

5. TROUBLE SHOOTING

For queries on Smoke/Heat alarm related issues refer to the specific owner's manual.

Fault	Action
When I press the learn in button the amber LED on the base does not flash.	Wait for at least 2 minutes to allow the system to respond. If there is no response within 5 minutes, ensure unit is correctly positioned. Attempt to learn in again by pressing the button.
When I press the test button on the Smoke/Heat alarm no other alarms sound.	Ensure all alarms are powered up (green and red LEDs indicating as per Smoke/Heat alarm owners manual. Repeat learn in process in section 3.2 or 3.3 as appropriate.

When I press the test button on the Smoke/Heat alarm some alarms sound and others do not.	Remove the alarms and repeat learn in process in the section 3.2 or 3.3 as appropriate.
The unit gives an occasional single chirp but there is no amber flash.	This indicates a problem with the Smoke/Heat alarm. Refer to the Smoke/Heat alarm owner's manual.
The amber LED flashes and base chirps.	Low battery. Replace base.
Base emits a double beep.	Base is not learnt in correctly. Repeat the learn in process in section 3.2 & 3.3.

If you have any questions about the operation of your Smoke/Heat alarms or DS700RF RF interlink base please contact the Technical Support line on **+44 (0)1452 887570** or email us via the link on our website **www.brkelectronics.eu**

6. DISPOSAL



This product, the batteries and other accessories must not be disposed of as unsorted municipal waste and must be collected separately at the end of the product's life. Contact your local authority for information about collection points in your area.

7. LIMITED GUARANTEE

BRK (“the BRK Brands Europe Ltd products”) as distributed by Sprue Safety Products Ltd (“the Distributor”), are guaranteed by the Distributor to be free from defects in materials and workmanship under normal use and service for a period of five years from the date of purchase.

Neither the Distributor nor BRK Brands Europe Ltd make any other express guarantees for this product. No agent, representative, dealer or employee from the Distributor or BRK Brands Europe Ltd has the authority to increase or alter the obligations or limitations of the Guarantee. The Distributor’s obligation of this guarantee shall be limited to the repair or replacement of any part of the DS700RF base which is found to be defective in materials or workmanship under normal use and service during the five year period commencing from date of purchase. The Distributor shall not be obligated to repair or replace DS700RF bases which are found to be in need of repair because of damage, unreasonable use, modifications or alterations occurring after the date of purchase. This warranty does not affect a customer’s statutory rights in any way.

How to obtain guarantee service

If service is required, return the product to your supplier. The Distributor makes no guarantee, express or implied, written or oral, including that of merchantability or fitness for any particular purpose with respect to battery. In the event of a problem with your DS700RF base or you have any questions concerning its use, care and service please consult this manual.

If you require any further help or clarification please write to:
Sprue Safety Products Ltd, Unit 6, Carter Court - Davy Way, Waterwells Business Park, Quedgeley, Gloucester, GL2 2DE, United Kingdom or phone our Helpline on:
+44 (0)1452 887 570

www.brkelectronics.eu

Please note that specifications may be subject to change.

8. TECHNICAL SPECIFICATION

Power: Independent 10 year (battery for life) lithium cell.

Temperature: (operating):- 0°C - 40°C

Humidity: 0-95% (non condensing)

Warning: Visual and audible low battery warning

Radio Frequency: 868MHz

Wireless Range: Minimum 150m open air

Dimensions: 140mm (D) x 30mm (H)

Approvals: Independently tested and compliant with EMC, Electrical Safety and Radio Regulations to include requirements of the R&TTE Directive.

EN300220 v2.3.2 (2010.02)

EN301489-1

EN301489-3

EN50130-4

EN60065-1



Sprue Safety Products Ltd
6 Carter Court, Davy Way
Waterwells Business Park
Gloucester GL2 2DE UK

A Sprue Safety Products Brand

